

THIRD SEMESTER DIPLOMA EXAMINATION IN ENGINEERING/  
TECHNOLOGY—MARCH, 2015

**MACHINE DRAWING**

(Common to ME and AU)

[Time : 3 hours

(Maximum marks : 100)

- [Note :—1. All dimensions are in mm.  
2. First angle projection is to be followed.  
3. Missing data if any may be suitably assumed.  
4. Both sides of the drawing sheet may be used.  
5. Sketches are in 2 to 4 pages.]

	Marks
UNIT – I	
I Draw the following locking arrangements of nut in freehand :	
(a) Lock nut (c) Nut with spring washer	
(b) Castle nut	(3×5=15)
OR	
II Draw the following rivet heads in proportional dimension :	
(a) Snap head (c) Rounded countersunk head	
(b) Flat head	(3×5=15)
UNIT – II	
III Sectional isometric view of a Gib and cotter joint is shown in figure -1. Draw the top half sectional view and an end view.	30
OR	
IV A Pin type flexible coupling is shown in figure-2. Assemble the parts, draw top half sectional elevation and an end view.	30
UNIT – III	
V Isometric view of a plummer block is shown in figure-3. Draw the right half sectional elevation, full plan and an end view. Prepare the bill of material.	40
OR	
VI Detailed view of a connecting rod is given in figure-4. Assemble the parts and draw the right half sectional elevation and a plan. Prepare item list.	40
UNIT – IV	
VII Draw elementary symbols of the following :	
(a) Single V butt weld (d) Single J butt weld	
(b) Square butt weld (e) Fillet weld.	
(c) Single bevel butt weld	(5×3=15)
OR	
VIII Draw the single line orthographic layout for the delivery side of water pump installation by using symbols.	15

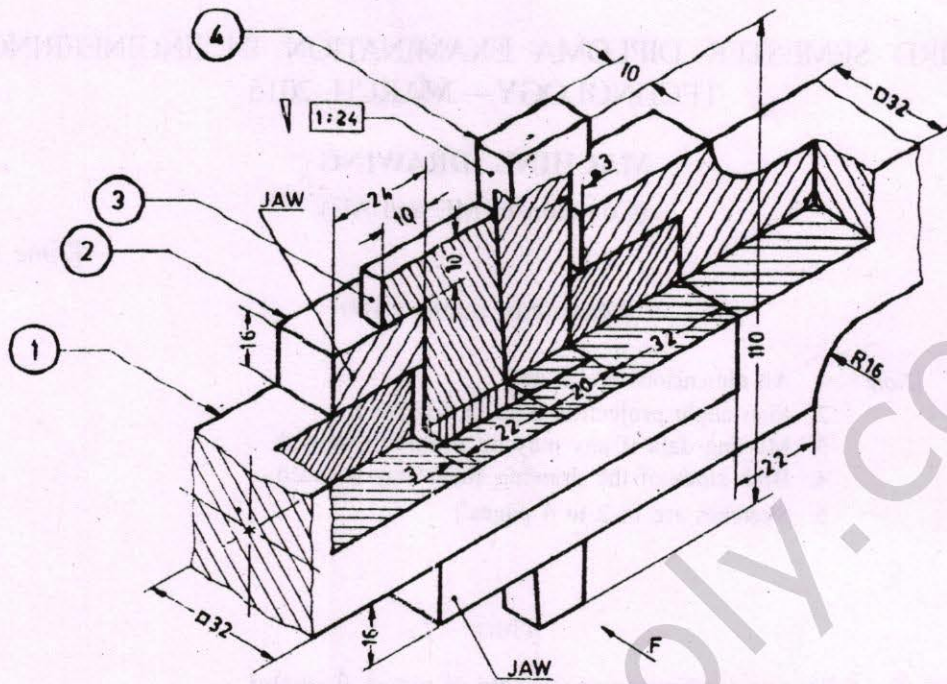

Figure-1. GIB AND COTTER JOINT.

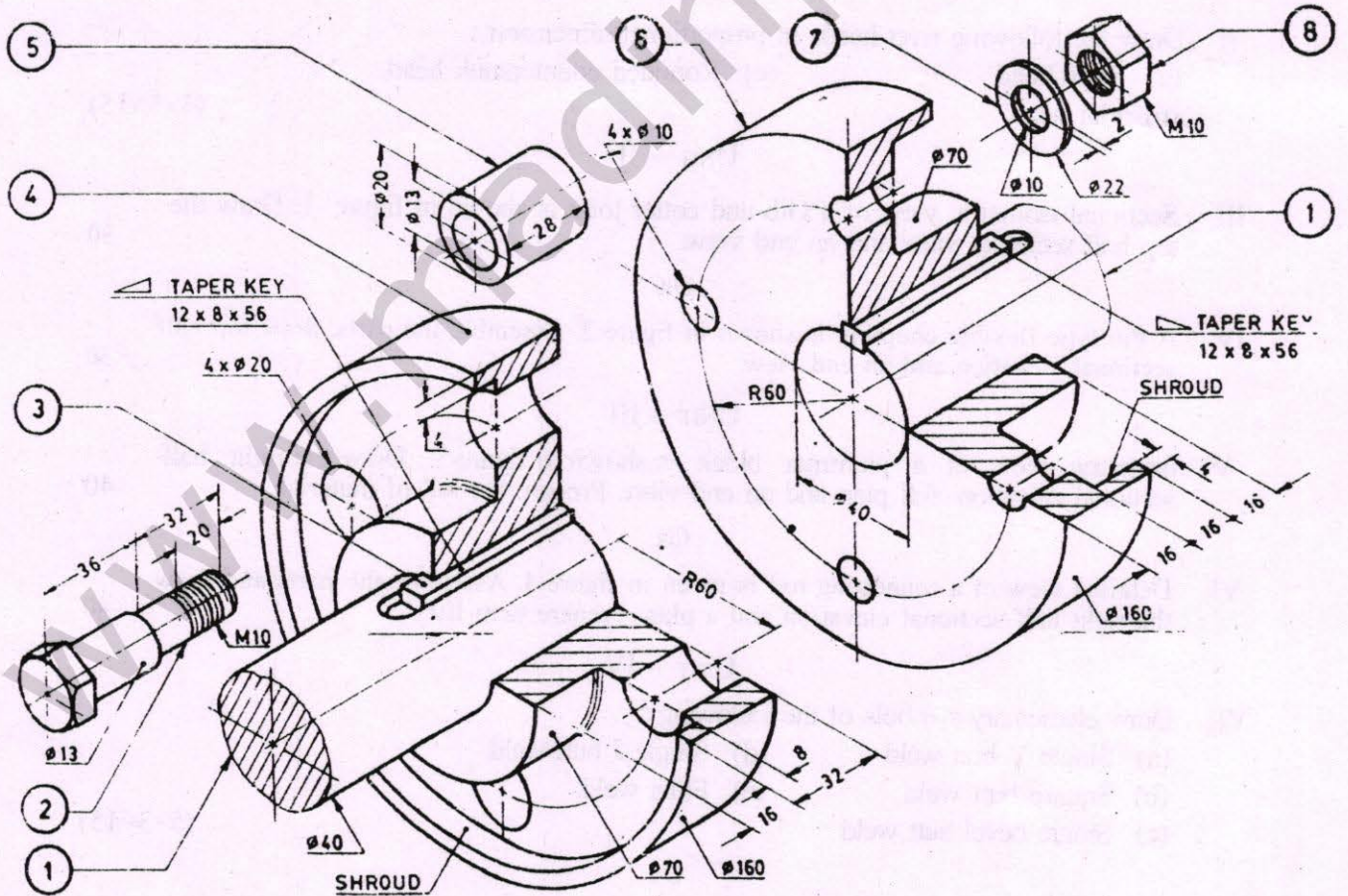

Figure-2. Pin type Flexible coupling.

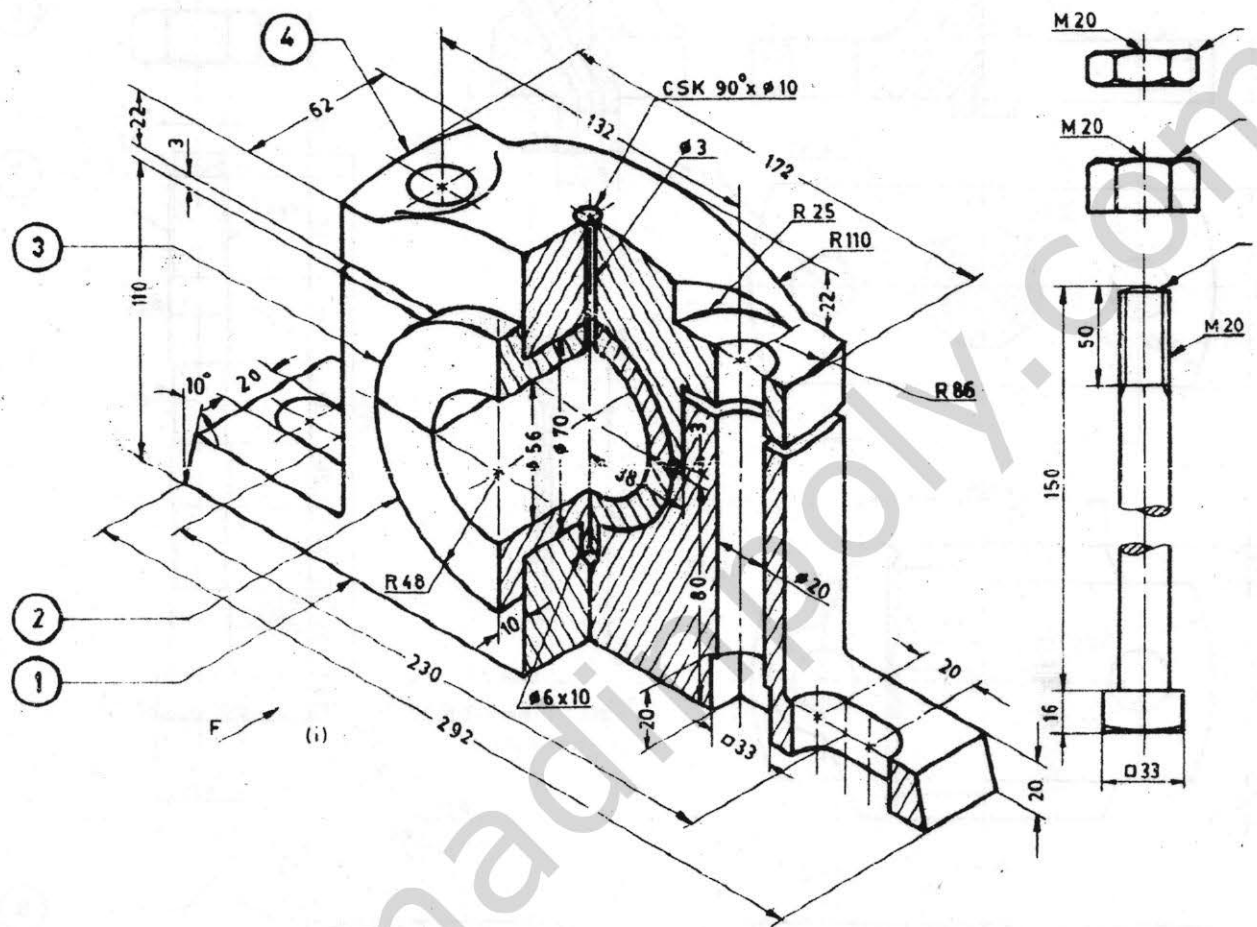

Figure - 3. PLUMMER BLOCK.

WWW.MADEININDIA.COM

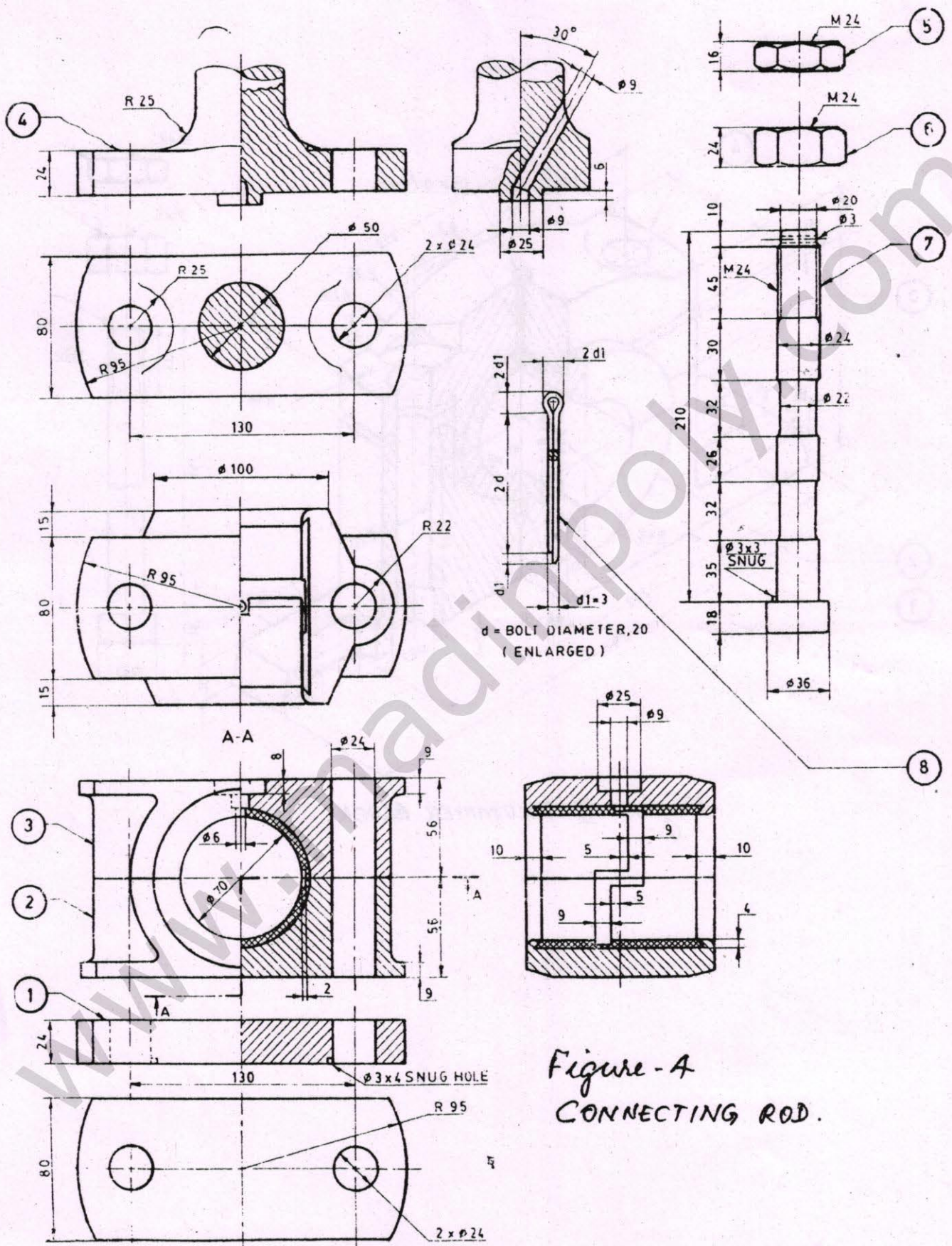

Figure - A  
CONNECTING ROD.